



WORM REDUCERS RATINGS & SELECTION



EXPLANATION AND USE OF RATINGS AND SERVICE FACTORS

Gear unit selection is made by comparing actual transmitted loads with catalogue ratings. However, it is important to realise that catalogue ratings are based on a standard set of loading conditions, which inevitably change for different applications. Therefore, a service factor must be used to calculate a theoretical transmitted load, or equivalent load, before comparing with catalogue ratings.

Equivalent load = actual load x service factor.

Mechanical Ratings and Service Factors

Mechanical ratings measure capacity in terms of life and/or strength, assuming 10 hours per day continuous running under uniform load conditions, when lubricated with an approved oil and working at a maximum oil temperature of 100°C. For normal application lubricant equivalent to **ISO VG 320** should be used. See publication G/105 for details.

When a unit transmits less than catalogue rating its life is increased, if the running time is more than 10 hours per day, a service factor from Table 1 ensures selection of a unit which transmits less than catalogue rating, its life therefore is increased consistent with the increased daily running time. If this increased life is not required, the service factor need not be used. Similarly the use of a service factor for less than 10 hours per day gives a reduced life consistent with the reduced daily running time.

Catalogue ratings allow 100% overload at starting, braking or momentarily during operation, up to 10 times per day. The unit selected must therefore have a catalogue rating equal to, or greater than half the maximum overload.

If the unit is subjected to sustained overloads or to shock loads, these must be reflected in the chosen service factor if overloads can be calculated or estimated then the actual loads should be used instead of a factor. When detailed operating conditions are not available Table 3, page 4 gives a guide to the load characteristics of many varied applications, and should be used to determine appropriate service factors from table 1.

Thermal Ratings and Service Factors

Thermal ratings measure the unit's ability to dissipate heat, if they are exceeded the lubricant may overheat and break down, with consequent life failure.

Both mechanical and thermal ratings are given for unit sizes 1000 and above, lower rating deciding the unit's capacity. For other units mechanical ratings are over-riding and thermal ratings are not relevant.

Thermal ratings are affected by ambient temperature and not by mechanical considerations such as increased running time or shock loads. Catalogue ratings assume 20°C ambient temperature, the oil (or grease) temperature then rising as the units transmit power and generate heat.

If the ambient temperature is more than 20°C, a lower temperature rise is allowed therefore less power may be transmitted. Similarly in cooler temperatures the thermal ratings may be exceeded. When selecting units use a service factor from Table 2 to calculate equivalent loads.

For unit sizes 112 to 800, the relevant mechanical and thermal service factors are selected from tables and whichever is higher is applied to find out the equivalent output power and output torque. For unit sizes 1000 to 1700, mechanical service factor should be applied to mechanical ratings and thermal service factor to thermal ratings. Higher of these should be considered for selection of the unit.

Thermal ratings assume fan cooling which is a standard feature of worm gear units.

For intermittent running with ample cooling time during rest periods, thermal ratings may be exceeded without overheating, and since the fan is ineffective it can usually be removed.

Adaptable Gear Units

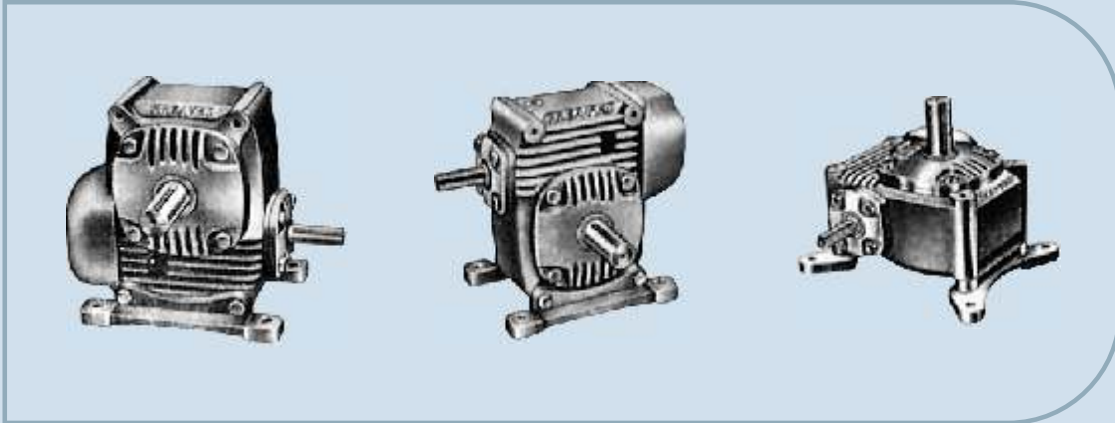

Solid Foot Gear Units



Heavy Duty Gear Units





Table 1. Mechanical Service Factors

Prime Mover	Duration of Service - hrs per day	Load classification-driven machine		
		Uniform Shock	Moderate Shock	Heavy Shock
Electric motor, steam turbine or hydraulic motor	Under 3	0.80	1.00	1.50
	3 to 10	1.00	1.25	1.75
	Over 10	1.25	1.50	2.00
Multi-cylinder internal combustion engine	Under 3	1.00	1.25	1.75
	3 to 10	1.25	1.50	2.00
	Over 10	1.50	1.75	2.25
Single cylinder internal combustion engine	Under 3	1.25	1.50	2.00
	3 to 10	1.50	1.75	2.25
	Over 10	1.75	2.00	2.50

Table 2. Thermal Service Factors

Ambient temp. °C	Running Time in any Hour				
	100%	80%	60%	40%	20%
10	0.87	0.73	0.62	0.54	0.48
20	1.00	0.84	0.71	0.62	0.56
30	1.16	0.97	0.82	0.72	0.64
40	1.35	1.13	0.96	0.84	0.75
50	1.62	1.35	1.16	1.00	0.90

For applications where high inertia loads are to be absorbed. e.g. crane travel drives, slewing motions, etc. unit selection should be made by Premium engineers.

When selecting units use the actual load transmitted and not the rating of the prime mover, and wherever possible use output torque (Nm). Catalogues also give input power (KW), being the power which the prime mover must provide to allow for losses in the gear unit. When units transmit less than rated output torque the input power is reduced, and although a gear unit is marginally less efficient at part load a, pro-rata reduction is usually sufficiently accurate to decide the capacity of the prime mover.

Examples

Example (Sizes 112 to 800)

A Premium speed reducer, with the worm under the wheel, is required for a conveyor handling non-uniform material and which is operating 8 hours/day. The motor speed is 1000 rpm and power required at the output shaft is 4 KW at 29 rpm, Ambient temperature is 50°C or less.

$$\text{Ratio required} = \frac{1000}{29} = 34,48/1 \quad (\text{35/1 approx.})$$

From table 3, page 4, load on the unit is moderate shock. Hence mechanical service factor is 1.25 from table 1 page 3, But thermal service factor corresponding to 50°C ambient temperature is 1,62 from table 2, page 3. Therefore the higher of the two i.e. 1.62 is selected as service factor.

$$\begin{aligned} \text{Equivalent output power} &= 4 \times 1.62 \\ &= 6.48 \text{ KW} \\ \text{Equivalent output torque} &= \frac{6.48 \times 9550}{29} \\ &= 2134 \text{ Nm} \end{aligned}$$

Adaptable Gear Units

From rating table on page 7, U700 unit with allowable torque 2960 Nm is selected.

$$\begin{aligned} \text{Required input power} &= \\ 2134 \times 11.0 &= 4.895 \text{ KW} \\ 2960 \times 1.62 & \end{aligned}$$

Nearest standard motor is 5.5 KW

Example (Sizes 1000 to 1700)

A Premium speed reducer is required to drive a bucket elevator which is not uniformly loaded and operates for 10 hours a day, transmitting 38 KW at 31 rpm and driven by motor.

The ambient temperature is 40°C or less.

$$\begin{aligned} \text{Unit Ratio} &= 1500/31 = 48.4/1 \\ & \quad (50/1 \text{ approx.}) \end{aligned}$$

From table 3 on page 4, the load is moderate shock load. Hence the mechanical service factor is 1.25

$$\begin{aligned} \text{Equivalent output power (mechanical)} & \\ &= 38 \times 1.25 = 47.5 \text{ KW} \end{aligned}$$

$$\begin{aligned} \text{Equivalent output torque (mechanical)} & \\ &= 47.5 \times 9550/31 = 14633 \text{ Nm} \end{aligned}$$

Hence unit size 1400 which gives 15000 Nm output torque with 57.9 KW input power may be suitable.

Thermal service factor from table 2 is 1.35 for an ambient temperature of 40°C.

$$\begin{aligned} \text{Equivalent output power (thermal)} & \\ &= 38 \times 1.35 = 51.3 \text{ KW} \end{aligned}$$

$$\begin{aligned} \text{Equivalent output torque (thermal)} & \\ &= \frac{51.3 \times 9550}{31} = 15804 \text{ Nm} \end{aligned}$$

Since the thermal output torque rating of 1400 unit is only 10700 Nm, which is less than 15804 Nm, 1700 unit size is selected. Mechanical output torque rating of 1700 unit is 29100 Nm and mechanical input power is 109 KW,

$$\begin{aligned} \text{Required input power} & \\ 14633 \times 109 & \\ 29100 \times 1.25 & = 43.849 \text{ KW} \end{aligned}$$

Nearest standard motor is 45 KW

Enquiries

It is recommended that as much as possible of the following Information be given in the enquiry or order so that a check can be made and advice given on the most suitable size of gear box for any application.

1. Type of prime mover.
2. Horse-power of prime mover.
3. Output torque required from driven member.
4. Input speed of gear unit.
5. Output speed of gear unit.
6. Configuration of drive required and shaft disposition.
7. Total daily hours of running. If running is Intermittent, details of duty cycle should be given. Particulars of any abnormal starting load should be stated.
8. Details of reversing or shock loads.
9. Details of any external loads imposed on gear unit.
10. Details of any abnormal operating conditions, e.g. ambient temperature, humidity, etc.

Nominal ratios are shown in the rating table for convenience, Details of exact standard ratios are given on page 9.

Where external overhung loads are to be supported by the gear unit, a check must be made using data given on page 10 to ensure that these loads are within the capacity of the unit.



Load Classification by applications

U = Uniform load

H = Heavy shock load

* 24 hours/day Service Factor Only

‡ Use 1.25 Service Factor

M = Moderate shock load

† = Refer to Greaves

** Use 1.00 Service Factor

‡‡ Use 1.50 Service Factor

Driven machine	Type of load	Driven machine	Type of load	Driven machine	Type of load
Agitators		assembly	M	belt	M
Agitators		belt		disc	
pure liquids	U	M		U	
liquids and solids	M	bucket	M	reciprocating	H
liquids-variable density	M	chain	M	screw	M
Blowers		flight		Food industry	
centrifugal	U	M		beef slicer	M
lobe		live roll	†	cereal cooker	U
M		oven		dough mixer	M
vane		M		meat grinders	M
U		reciprocating	H	Generators-not welding	U
Brewing and distilling		shaker	H	Hammer mills	H
bottling machinery	U	Cranes		Hoists	
brew kettles-continuous duty		main hoists	U	heavy duty	H
U		bridge travel	†	medium duty	M
cookers-continuous duty	U	trolley travel	†	skip hoist	M
mash tubs-continuous duty	U	Crusher		Laundry washers	
scale hooper-frequent starts	M	ore		reversing	M
Can filling machines	U	H		Laundry lumbers	M
Cane knives	M	stone	H	Line shafts	
Car dumpers	H	sugar	M	driving processing equipment	M
Car pullers	M	Dredges		light	
Clarifiers	U	cable reels	M	U	
Classifiers	M	conveyors	M	other line shafts	U
Clay working machinery		cutter head drives	H	Lumber Industry	
brick press	H	jig drives	H	barkers-hydraulic	
briquette machine	H	manoeuvring winches	M	mechanical	M
clay working machinery	M	pumps	M	burner conveyor	M
pug mill	M	screen drive	H	chain sow and drag sow	H
Compressors		stackers	M	Chain transfer	H
centrifugal	U	utility winches	M	craneway transfer	H
lobe		Duty dock crow		de-barking drum	H
M		main hoist	**	edger feed	M
reciprocating		auxiliary hoist	**	gang feed	M
multi-cylinder		boom, luffing		green chain	M
single-cylinder		rotating, swing or slew	‡	live rolls	H
Conveyors uniformly		tracking, drive wheels	‡‡	log deck	H
loaded or fed		Elevators		log haul-Incline	H
apron	U	bucket-uniform load	U	log haul-well type	H
assembly	U	bucket-heavy load	M	log turning device	H
belt		bucket-continuous	U	main log conveyor	H
U		centrifugal discharge escalators	U	off bearing rolls	M
bucket	U	freight	M	planer feed chains	M
chain	U	gravity discharge	U	planer floor chains	M
flight		man lifts	†	planer tilting hoist	M
U		passenger	†	re-saw merry-go-round	
oven		Fans		conveyor	M
U		centrifugal	U	roll cases	H
Screw		cooling towers		slab conveyor	H
Conveyors-heavy duly		Induced draft	†	small waste conveyor-belt	U
not uniformly fed		forced draft	†	small waste conveyor-chain	M
apron	M	Induced draft	M	sorting table	M
		large, mine. etc.	M	tipple hoist conveyor	M
		large, Industrial	M	tipple hoist drive	M
		light, small diameter	U	transfer conveyors	M
		Feeders		transfer rolls	M
		apron	M		



Load Classification by applications

Driven machine	Type of load	Driven machine	Type of load	Driven machine	Type of load
tray drive	M	converting machine		collectors	U
trimmer feed	M	except cutters, platers	M	dewatering screws	M
waste conveyor	M	conveyors	U	scum breakers	M
Machine tools		couch	M	slow or rapid mixers	M
bending roll	M	cutters-plates	H	thickeners	M
punch press-gear driven	H	cylinders	M	vacuum filters	M
notching press-belt driven	-	dryers	M	Screens	
plate planers	H	felt stretcher	M	air washing	U
topping machine	H	felt whipper	H	rotary-stone or gravel	M
other machine tools		jordans	M	travelling water intake	U
main drives		log haul	H	Slab pushers	M
auxillary drives		presses	M	Steering gear	†
Metal mills		pulp machine reel	M	Stokers	
draw bench carriage		stock chest	M	U	
and main drive	M	suction roll	M	Sugar Industry	
pinch, dryer and scrubber		washers and thickeners	M	cone knives	M
rolls reversing	†	winders	M	Crushers	
slitters	M	Printing presses	†	mills*	
table conveyors		Pullers		M	
non-reversing		barge haul	H	Textile Industry	
group drives	M	Pumps		batches	M
Individual drives	H	centrifugal	U	calenders	M
reversing	†	proportioning	M	cards	M
wire drawing and		reciprocating		dry cans	M
flattening machine	M	single acting 3 or		dryers	M
wire winding machine	M	more cylinders	M	dyeing machinery	M
Mills-rotary type		double acting 2 or		knitting machines	†
ball*		more cylinders	M	looms	M
M		single acting 1 or 2		mangles	M
cement kilns*	M	cylinders	†	nappers	M
dryers and coolers*	M	double acting single		pads	
kilns, other than cement	M	cylinder	†	M	
pebble*		rotary		range drives	-
rod*		gear type	U	slashers	M
plain	M	lobe,vane	U	soapers	M
wedge bar	M	Rubber and plastics		spinners	M
tumbling barrels	H	Industries		tenfer frames	M
Mixers		crackers*	H	washers	M
concrete mixers continuous	M	laboratory equipment	M	winders	M
concrete mixers-intermittent	M	mixed mills*	H	Windlass	†
constant density	U	refiners*	M		
variable density	M	rubber calenders*	M		
Oil Industry		rubber mill 2 on line*	M		
chillers	M	rubber mill 3 on line*	U		
oil well pumping	†	sheeter*	M		
paraffin filter press	M	fire building machines	†		
rotary kilns	M	fire and tube press			
Paper mills		openers	†		
agitators, (mixers)	M	tubers and strainers*	M		
barker-auxiliaries-hydraulic	M	worming mills*	M		
barker-mechanical	H	Sand muller	M		
barker drum	H	Sewage disposal			
beater and pulper	M	equipment			
bleacher	U	bar screens	U		
calenders	M	chemical feeders	U		
calenders-super	H				



Ratings at 1500 RPM Input Speed

Nominal Ratio RPM	Nominal Output	Capacity	Unit Size					
			112	162	200	237	287	337
5/1	300	Input Power KW	0.548	1.243	2.72	4.05	5.51	10.8
		Output Torque Nm	16.6	38.4	77.5	121	171	312
7.5/1	200	Input Power KW	-	1.081	1.93	2.92	4.76	7.24
		Output Torque Nm	-	45.8	82.6	126	203	311
10/1	150	Input Power KW	0.432	1.052	1.88	2.60	3.82	6.29
		Output Torque Nm	24.6	61.8	112	146	228	354
15/1	100	Input Power KW	0.329	0.942	1.50	2.30	3.71	5.62
		Output Torque Nm	25.0	73.5	120	186	301	462
20/1	75	Input Power KW	0.300	0.655	1.40	2.30	3.71	5.62
		Output Torque Nm	28.3	67.1	142	233	294	447
25/1	60	Input Power KW	0.266	0.578	1.14	1.83	2.74	3.91
		Output Torque Nm	30.2	70.8	142	231	352	511
30/1	50	Input Power KW	0.217	0.515	0.94	1.46	2.31	3.50
		Output Torque Nm	28.5	73.0	137	214	348	537
40/1	37.5	Input Power KW	0.164	0.427	0.70	1.06	1.68	2.55
		Output Torque Nm	25.4	76.1	129	197	321	498
50/1	30	Input Power KW	0.112	0.309	0.53	0.820	1.31	1.91
		Output Torque Nm	20.9	65.0	115	180	301	446
60/1	25	Input Power KW	0.096	0.240	0.38	0.60	1.00	1.55
		Output Torque Nm	14.8	43.5	75.2	121	264	412
70/1	21.4	Input Power KW	0.090	0.206	0.35	0.53	1.81	1.18
		Output Torque Nm	14.6	43.7	74.0	118	198	305

Nominal Ratio RPM	Nominal Output	Capacity	Unit Size				
			400	500	600	700	800
5/1	300	Input Power KW	12.8	20.9	38.4	51.5	70.4
		Output Torque Nm	372	629	1130	1560	2140
7.5/1	200	Input Power KW	9.18	17.5	26.3	41.5	54.4
		Output Torque Nm	405	769	1190	1860	2450
10/1	150	Input Power KW	8.36	15.9	23.1	31.9	41.3
		Output Torque Nm	467	914	1330	1840	2390
12.5/1	120	Input Power KW	7.25	-	-	-	-
		Output Torque Nm	530	-	-	-	-
15/1	100	Input Power KW	6.67	11.3	20.0	27.6	37.1
		Output Torque Nm	541	927	1700	2360	3190
20/1	75	Input Power KW	5.81	10.4	15.9	21.5	29.4
		Output Torque Nm	618	1130	1800	2370	3280
25/1	60	Input Power KW	4.76	8.00	12.5	19.7	26.9
		Output Torque Nm	616	1060	1680	2680	3710
30/1	50	Input Power KW	4.25	7.45	11.8	16.2	21.6
		Output Torque Nm	641	1160	1880	2610	3500
35/1	42.9	Input Power KW	-	6.71	10.3	14.2	-
		Output Torque Nm	-	1190	1880	2580	-
40/1	37.5	Input Power KW	3.50	5.72	9.64	13.7	17.9
		Output Torque Nm	673	1110	1960	2830	3740
50/1	30	Input Power KW	2.68	4.74	7.81	11.9	15.7
		Output Torque Nm	603	1110	1900	2980	3950
60/1	25	Input Power KW	2.29	4.16	6.24	9.4	13.2
		Output Torque Nm	593	1140	1750	2720	3870
70/1	21.4	Input Power KW	1.98	3.40	5.35	7.75	10.9
		Output Torque Nm	577	1030	1670	2490	3540



Ratings at 1500 RPM Input Speed

Nominal Ratio	Nominal Output RPM	U & V TYPE UNIT SIZE				O TYPE UNIT SIZE		
		1000	1200	1400	1700	1000	1200	1400
Input Power	- Mechanical	KW	KW	KW	KW	KW	KW	KW
Output Torque	- Mechanical	Nm	Nm	Nm	Nm	Nm	Nm	Nm
Input Power	- Thermal	KW	KW	KW	KW	KW	KW	KW
Output Torque	- Thermal	Nm	Nm	Nm	Nm	Nm	Nm	Nm
5/1	300	121	180	249	-	121	180	249
		3690	5470	7460	-	3690	5470	7460
		88.2	124	Forced	-	88.2	122	Forced
		2680	3790	Lubrication	-	2680	3720	Lubrication
7.5/1	200	89	138	186	-	89	138	186
		4030	6220	8420	-	4030	6220	8420
		74.8	108	155	-	74.8	106	131
		3380	4900	7030	-	3380	4790	5990
10/1	150	62.3	113	152	318	62.3	113	152
		3630	6630	8940	19200	3630	6630	8940
		67.3	97.8	146	193	67.3	94.6	123
		3920	5750	8590	11600	3920	5600	7290
12.5/1	120	-	90.6	141	-	-	90.6	141
		-	6760	10700	-	-	6760	10700
		-	90.7	125	-	-	87.3	98
		-	6770	9490	-	-	6570	7490
15/1	100	55.5	79.4	146	242	55.5	79.6	146
		4800	6900	12800	21200	4800	6900	12800
		54.1	81.1	115	164	52.3	72.5	87.6
		4680	7040	10100	14300	4550	6350	7710
20/1	75	52.8	82.5	118	206	52.8	82.5	118
		6050	9490	13600	23700	6050	9490	13600
		45.5	67	100	131	40.8	55.1	72.3
		5190	7690	11500	15000	4700	6390	8400
25/1	60	43.5	65.9	93.1	152	43.5	65	93.4
		6070	9290	13100	21600	6070	9290	13100
		36.4	54.4	79.5	104	30.9	42.7	56.4
		5060	7760	11200	14600	4340	6170	8010
30/1	50	36.9	59.3	84.4	148	36.9	59.3	84.4
		6080	9890	14600	24700	6080	9890	14600
		31.6	49	69.3	96.6	26.1	36.8	47.2
		5180	8140	11900	16000	4330	6200	8230
35/1	42.9	-	47.1	-	-	-	47.1	-
		-	9250	-	-	-	9250	-
		-	42.8	-	-	-	30.6	-
		-	8390	-	-	-	6100	-
40/1	37.5	31.8	49.9	70	100	31.8	49.9	70
		6830	10900	15200	22000	6830	10900	15200
		24.6	3702	50	74.4	18.5	25.7	31.7
		5250	8060	10700	16200	4010	5660	6990
50/1	30	26.6	40.4	57.9	109	26.6	40.4	57
		6880	10600	15000	29100	6880	10600	15000
		20.9	31	41	64.5	14.5	19.6	24.1
		5350	8100	10700	16800	3770	5220	6420
60/1	25	22.5	34.4	52.6	69.6	22.5	34.4	52.6
		6750	10400	16300	27900	6450	10400	16300
		18.1	26	38.4	49.3	11.5	15	20.7
		5390	7740	11900	17200	3480	4560	6470
70/1	21.4	18.5	29.7	43.8	74.2	18.5	29.7	43.8
		6340	10400	15200	26200	6340	10400	15200
		17.2	25.4	32.4	47.3	9.92	13.2	15.5
		5850	8790	11100	16200	3440	4700	5450



Ratings at 1000 RPM Input Speed

Nominal Ratio RPM	Nominal Output	Capacity	Unit Size					
			112	162	200	237	287	337
5/1	200	Input Power KW	0.432	0.986	2.16	3.21	4.23	8.62
		Output Torque Nm	19.4	44.9	90.9	142	195	369
7.5/1	133.3	Input Power KW	-	0.846	1.52	2.30	3.75	5.73
		Output Torque Nm	-	53.1	95.9	147	237	364
10/1	100	Input Power KW	0.338	0.824	1.47	2.04	3.00	4.94
		Output Torque Nm	28.4	71.2	129	169	264	411
15/1	66.7	Input Power KW	0.257	0.736	1.16	1.74	2.91	4.41
		Output Torque Nm	28.5	84.2	137	213	346	532
20/1	50	Input Power KW	0.238	0.508	1.10	1.74	2.16	3.26
		Output Torque Nm	32.2	76.4	163	266	336	513
25/1	40	Input Power KW	0.210	0.506	0.90	1.45	2.17	3.10
		Output Torque Nm	34.3	89.0	161	263	403	585
30/1	33.3	Input Power KW	0.173	0.458	0.74	1.16	1.82	2.76
		Output Torque Nm	32.2	93.0	155	244	397	612
40/1	25	Input Power KW	0.126	0.338	0.56	0.84	1.33	2.02
		Output Torque Nm	27.7	85.9	146	223	364	566
50/1	20	Input Power KW	0.088	0.228	0.410	0.65	1.03	1.52
		Output Torque Nm	18.3	68.4	125	204	340	505
60/1	16.7	Input Power KW	0.074	0.190	0.296	0.450	0.750	1.14
		Output Torque Nm	16.8	49.4	84.8	130	278	433
70/1	16.7	Input Power KW	0.067	0.162	0.257	0.420	0.610	0.960
		Output Torque Nm	16.3	47.9	82.5	136	225	346

Nominal Ratio RPM	Nominal Output	Capacity	Unit Size				
			400	500	600	700	800
5/1	200	Input Power KW	10.3	16.8	29.8	41.6	56.8
		Output Torque Nm	446	754	1310	1880	2580
7.5/1	133.3	Input Power KW	7.30	14.0	20.8	33.0	43.3
		Output Torque Nm	479	912	1410	2210	2920
10/1	100	Input Power KW	6.61	12.6	18.2	25.2	32.6
		Output Torque Nm	550	1080	1560	2180	2820
12.5/1	80	Input Power KW	5.71	-	-	-	-
		Output Torque Nm	619	-	-	-	-
15/1	66.7	Input Power KW	5.27	8.88	15.7	21.8	29.3
		Output Torque Nm	632	1080	1980	2760	3740
15/1	66.7	Input Power KW	5.27	8.88	15.7	21.8	29.3
		Output Torque Nm	632	1080	1980	2760	3740
20/1	50	Input Power KW	4.59	8.22	12.6	16.9	23.1
		Output Torque Nm	719	1320	2100	2770	3830
25/1	40	Input Power KW	3.78	6.31	9.90	15.4	21.1
		Output Torque Nm	716	1230	1960	3120	4330
30/1	33.3	Input Power KW	3.38	5.80	8.82	12.3	17.0
		Output Torque Nm	744	1330	2070	2910	4080
35/1	28.6	Input Power KW	-	5.20	7.84	11.0	-
		Output Torque Nm	-	1340	2080	2960	-
40/1	25	Input Power KW	2.78	4.53	7.35	10.6	14.1
		Output Torque Nm	777	1280	2196	3240	4340
50/1	20	Input Power KW	2.13	3.75	6.16	9.31	12.3
		Output Torque Nm	693	1270	2190	3430	4540
60/1	16.7	Input Power KW	1.80	3.27	4.91	7.38	10.4
		Output Torque Nm	678	1310	2010	3120	4450
70/1	14.3	Input Power KW	1.56	2.67	4.21	6.07	8.49
		Output Torque Nm	657	1180	1910	2850	4050

Ratings at 1000 RPM Input Speed

Nominal Ratio	Nominal Output RPM	U & V TYPE UNIT SIZE				O TYPE UNIT SIZE		
		1000	1200	1400	1700	1000	1200	1400
Input Power	- Mechanical	KW	KW	KW	KW	KW	KW	KW
Output Torque	- Mechanical	Nm	Nm	Nm	Nm	Nm	Nm	Nm
Input Power	- Thermal	KW	KW	KW	KW	KW	KW	KW
Output Torque	- Thermal	Nm	Nm	Nm	Nm	Nm	Nm	Nm
5/1	200	97.8 4460 68 3090	145 6630 98.7 4500	202 9070 143 6400	- - - -	97.8 4460 68 3090	145 6630 94.8 4330	202 9070 123 5500
7.5/1	133.3	71 4800 56 3780	109 7430 82.3 5570	148 10100 120 8130	- - - -	71 4800 56.9 3780	109 7430 78.5 5340	148 10100 102 6960
10/1	100	49.2 4290 50 4360	89.2 7860 74 6520	120 10600 112 9840	253 22900 155 14000	49.2 4290 50 4360	89.2 7860 101 6220	120 10500 946 8380
12.5/1	80	- - - -	71.3 7970 68.3 7610	110 12600 95.7 10900	- - - -	- - - -	71.3 7970 64.5 7230	110 12600 76.3 8720
15/1	66.7	43.6 5640 40 5160	62.5 8110 61 7920	114 15100 87.8 11500	190 25100 131 17200	43.6 5640 38.8 5030	62.5 8110 55 7160	114 15100 68 8940
20/1	50	41.6 7080 33.5 5710	65 11100 50.3 8610	92.5 15900 759 13100	161 27900 105 18000	41.6 7080 30.3 5180	65 11100 41.7 7190	92.5 15900 55.8 9670
25/1	40	34.3 7090 27 5580	51 10900 41 8700	73 15400 61 12800	120 25400 82 17300	34.3 7090 23.1 4810	51 10900 32.2 6910	73 15400 43.3 9180
30/1	33.3	29 7090 23.4 5710	46.4 11600 36.7 9110	66.1 17000 52.8 13500	116 29000 76.7 19100	29 7090 19.4 4750	46.4 11600 27.7 6930	66.1 17000 36.2 9390
35/1	28.6	- - - -	36.7 10800 32 9370	- - - -	- - - -	- - - -	36.7 10800 23 6810	- - - -
40/1	25	25 7930 18.3 5790	39 12600 28 9020	54.7 17800 38.3 12400	77.8 25700 58.1 19000	25 7930 13.8 4430	39 12600 19.7 6410	54.7 17800 25 8170
50/1	20	20.83 7960 15.8 5930	31.6 12300 23.2 9030	44.4 17400 31.9 12400	78.3 31100 49.3 19600	20.83 7960 11 4190	31.6 12300 15.1 5930	44.4 17400 19.2 7550
60/1	16.7	17.6 7770 13.6 5980	26.9 12000 19.6 8690	41 18900 29.6 13500	67 31100 43.6 20000	17.6 7770 8.7 3880	26.9 12000 11.6 5240	41 18900 16.3 7590
70/1	14.3	14.5 7270 12.7 6390	23.1 11900 19.2 9800	34 17500 25 12700	57.3 30200 37.1 19200	14.5 7270 7.5 3790	23.1 11900 10.2 5320	34 17500 12.6 6520



Actual Ratings of U900 & V900 Gearboxes

RATIO	CAPACITY	INPUT SPEEDS RPM			
		1500	1000	750	500
6.5/1	Input Power Kw	71.2	54.2	40.4	30.8
	Output Torque Nm	2750	3130	3090	3520
9/1	Input Power Kw	51.2	40.5	34	26
	Output Torque Nm	2780	3270	3640	4050
13/1	Input Power Kw	48.2	35.7	27.4	20
	Output Torque Nm	3620	4000	4060	4380
18/1	Input Power Kw	39	28.7	22.2	16
	Output Torque Nm	3980	4350	4450	4720
22.5/1	Input Power Kw	34.5	25.2	19.7	14
	Output Torque Nm	4340	4690	4850	5040
26/1	Input Power Kw	30.2	22.1	17.3	12.3
	Output Torque Nm	4310	4660	4810	5000
36/1	Input Power Kw	22.4	16.6	12.9	9.4
	Output Torque Nm	4200	4580	4700	4960
44/1	Input Power Kw	19.9	14.6	11.5	8.3
	Output Torque Nm	4450	4800	4970	5160
52/1	Input Power Kw	17.4	12.8	10.1	7.4
	Output Torque Nm	4440	4800	4970	5150
62/1	Input Power Kw	16.4	12.1	9.5	6.9
	Output Torque Nm	4920	5270	5470	5600

Power Rating of Worm Reduction, Size 2000 (20" Crs) Unit

ACTUAL RATIO	CAPACITY	INPUT SPEEDS RPM			
		1500	1000	750	500
12.167/1	Input Power : Mech - Kw	349	275	231	179
	Output Torque : Mech - Nm	2750	3130	3090	3520
	Input Power : Ther - Kw	276	207	164	120
	Output Torque : Ther - Nm	21900	24800	23800	25900
18/1	Input Power : Mech - Kw	252	186	150	109
	Output Torque : Mech - Nm	31700	35100	37500	40500
	Input Power : Ther - Kw	212	163	135	100
	Output Torque : Ther - Nm	25500	29500	33800	37200
23.333/1	Input Power : Mech - Kw	222	164	132	95.7
	Output Torque : Mech - Nm	35600	39500	41900	45300
	Input Power : Ther - Kw	150	116	97	73
	Output Torque : Ther - Nm	22100	25900	30800	34600
29.667/1	Input Power : Mech - Kw	198	147	119	86.2
	Output Torque : Mech - Nm	39600	44200	47000	50800
	Input Power : Ther - Kw	142	109	90	67
	Output Torque : Ther - Nm	24800	26800	35500	39500
35/1	Input Power : Mech - Kw	162	120	97.7	71
	Output Torque : Mech - Nm	37800	42000	44800	48400
	Input Power : Ther - Kw	124	95	80	60
	Output Torque : Ther - Nm	25500	29400	36700	40900
48.5/1	Input Power : Mech - Kw	95.1	70.4	57.1	41.9
	Output Torque : Mech - Nm	29800	33100	35200	38300
	Input Power : Ther - Kw	108	81.3	59	45
	Output Torque : Ther - Nm	30500	34700	36400	41100
60/1	Input Power : Mech - Kw	107	79.9	64.7	47.6
	Output Torque : Mech - Nm	40000	44400	46900	50900
	Input Power : Ther - Kw	67.6	52.6	45	35
	Output Torque : Ther - Nm	21400	25200	32600	37400
72/1	Input Power : Mech - Kw	90	67	55	40
	Output Torque : Mech - Nm	39200	43600	46100	49700
	Input Power : Ther - Kw	60.1	46.7	39	31
	Output Torque : Ther - Nm	21700	25400	32700	38500

Note : Service factors to be applied as given in example (sizes 1000 to 1700) in publication of Premium Energy Transmission Ltd.

Ratings Based on Input Speeds of 750 r.p.m.

Nom. Redn. Ratio	Nom. Output rpm	Capacity	Size of Unit											
			237	257	337	400	500	600	700	800	1000	1200	1400	1700
5	150	Input Power kW	2.7	3.7	7.3	8.8	14.1	26	34.8	47.8	62.7	123.6	171.8	—
		Output Torque Nm	167	224	412	492	839	1616	2093	2879	4888	7337	10247	—
7.5	100	Input Power kW	1.9	3.2	4.8	6.1	11.6	17.5	27.6	30.2	59.7	92.6	124.9	—
		Output Torque Nm	181	264	404	531	1010	1572	2465	3246	5248	8289	11645	—
10	75	Input Power kW	1.7	2.5	4.2	5.3	10.8	15.2	21.1	27.3	41.8	76.1	101.2	212.2
		Output Torque Nm	186	292	456	609	1194	1740	2420	3149	5110	8793	11919	26036
12.5	60	Input Power kW	—	—	—	4.77	—	—	—	—	—	89.82	93.1	—
		Output Torque Nm	—	—	—	633	—	—	—	—	—	9684	14167	—
15	50	Input Power kW	1.6	2.4	3.7	4.4	7.6	13.1	18.1	24.3	36.5	52.2	96	155.6
		Output Torque Nm	239	383	607	696	1204	2189	3050	4134	6237	9027	16008	28967
20	37.5	Input Power kW	1.5	1.8	2.7	3.8	6.8	10.4	14.1	19.2	34.8	53.9	77.2	135.2
		Output Torque Nm	300	369	565	790	1460	2301	3065	4244	6072	12005	17728	31228
25	30	Input Power kW	1.2	1.8	2.6	3.2	5.3	8.2	12.8	17.6	28.4	43.2	60.9	99.4
		Output Torque Nm	288	444	637	787	1358	2146	3444	4771	8117	11949	17091	26382
30	25	Input Power kW	1	1.5	2.4	2.8	5	7.8	10.7	14.1	24.1	36.7	55.1	96.8
		Output Torque Nm	265	433	671	817	1482	2401	3340	4602	7620	12767	18891	32512
35	21.4	Input Power kW	—	—	—	2.6	4.47	6.82	8.38	—	—	30.71	—	—
		Output Torque Nm	—	—	—	642	1613	2379	3235	—	—	11960	—	—
40	18.8	Input Power kW	0.7	1.1	1.7	2.4	3.8	6.4	9	11.8	20.8	32.9	46.9	85.1
		Output Torque Nm	242	396	620	854	1417	2496	3625	4889	6702	13086	19613	29328
50	15	Input Power kW	0.6	0.9	1.3	1.8	3.2	5.2	7.9	10.4	17.5	26.6	38	71.4
		Output Torque Nm	221	370	548	771	1418	2424	3606	5068	6947	13612	19930	30000
60	12.5	Input Power kW	0.4	0.7	1	1.8	2.8	4.2	6.3	8.8	14.9	22.6	34.4	65.7
		Output Torque Nm	180	316	508	766	1444	2238	3473	4967	6688	13537	21171	39408
70	10.7	Input Power kW	0.3	0.5	0.7	1.3	2.3	3.6	5.2	7.3	12.2	19.6	28.8	48.7
		Output Torque Nm	162	264	392	687	1333	2143	3201	4586	6172	13378	19996	34728
		Gear Life Hrs	2400	5000	7200	8200	8430	9680	9650	9660	8730	6810	6840	6645

Ratings Based on Input Speeds of 500 r.p.m.

Nom. Redn. Ratio	Nom. Output rpm	Capacity	Size of Unit											
			337	387	537	600	660	700	800	900	1000	1200	1400	1700
5	100	Input Power kW	2.1	2.9	5.7	6.7	11.1	20.4	27.3	37.4	55	97.3	135.6	—
		Output Torque Nm	190	258	475	569	971	1759	2434	3347	5714	8599	12041	—
7.5	66.7	Input Power kW	1.5	2.4	3.7	4.7	9	13.6	21.5	28.2	46.4	72.1	97.5	—
		Output Torque Nm	184	301	462	600	1160	1908	2840	3743	6073	9003	13507	—
10	50	Input Power kW	1.3	1.9	3.2	4.3	8.2	11.9	16.4	21.3	32.5	51.1	78.5	165.3
		Output Torque Nm	210	331	530	696	1354	1993	2777	3818	5675	10130	13756	30120
12.5	40	Input Power kW	—	—	—	3.67	—	—	—	—	—	48.28	71.88	—
		Output Torque Nm	—	—	—	777	—	—	—	—	—	9968	16274	—
15	33.3	Input Power kW	1.2	1.9	2.9	3.4	5.8	10.2	14.1	18.9	29.3	40.3	74	123.3
		Output Torque Nm	270	433	665	791	1370	2491	3477	4717	7134	10333	19258	33283
20	25	Input Power kW	1.2	1.4	2.1	3	6.3	8	11	16	26.8	41.7	69.5	104.3
		Output Torque Nm	338	416	636	884	1642	2607	3494	4828	6182	14028	20248	38762
25	20	Input Power kW	0.9	1.4	2	2.5	4.1	6.4	10	13.8	22.1	33.4	46.9	76.7
		Output Torque Nm	323	500	719	899	1535	2429	3901	5405	8213	13602	19469	32382
30	16.7	Input Power kW	0.8	1.2	1.8	2.2	3.9	6.1	8.4	11	18.6	30	42.5	74.8
		Output Torque Nm	288	488	755	921	1673	2714	3790	5083	6884	14490	21481	37038
35	14.3	Input Power kW	—	—	—	3	5.6	8.4	7.4	—	—	23.9	—	—
		Output Torque Nm	—	—	—	347	1706	2684	3770	—	—	13547	—	—
40	12.5	Input Power kW	0.6	0.9	1.3	1.8	3	5	7.1	9.3	15.4	25.5	36.4	60.1
		Output Torque Nm	271	443	696	869	1696	2913	4088	5429	6943	16682	22472	33264
50	10	Input Power kW	0.4	0.7	1	1.4	2.5	4.1	6.2	8.2	13.8	20.7	29.4	56.3
		Output Torque Nm	246	413	613	865	1592	2723	4276	5709	6991	15382	22449	43096
60	8.3	Input Power kW	0.3	0.5	0.8	1.1	2.2	3.3	4.9	6.9	11.8	17.8	26.9	56.3
		Output Torque Nm	187	337	538	857	1618	2911	3996	5573	6707	15274	23096	32149
70	7.1	Input Power kW	0.2	0.4	0.6	0.9	1.7	2.9	4.1	6.8	9.7	16.4	22.5	37.8
		Output Torque Nm	169	294	408	715	1389	2402	3690	5151	6196	15069	22604	39227

Ratings Based on Input Speeds of 300 r.p.m.

Nom. Redn. Ratio	Nom. Output rpm	Capacity	Size of Unit											
			237	287	337	400	500	600	700	800	1000	1200	1400	1700
5	60	Input Power kW	1.5	2.1	4.1	4.9	8	14.8	19.9	27.2	47.4	70.9	98.8	-
		Output Torque Nm	212	303	561	673	1151	2088	2886	3888	6838	10312	14483	-
7.5	40	Input Power kW	1.1	1.7	2.7	3.4	6.5	8.8	15.8	20.2	33.6	52.2	70.8	-
		Output Torque Nm	218	362	541	713	1362	2128	3347	4414	7188	11303	16028	-
10	30	Input Power kW	0.9	1.4	2.2	2.1	5.8	6.6	11.8	15.2	23.4	42	56.8	119.1
		Output Torque Nm	344	385	606	613	1563	2334	3267	4247	6907	11935	16238	35644
12.5	24	Input Power kW	-	-	-	3.62	-	-	-	-	-	33.31	51.77	-
		Output Torque Nm	-	-	-	802	-	-	-	-	-	11689	18116	-
15	20	Input Power kW	0.8	1.3	2	2.5	4.1	7.3	10	13.5	20.3	28.9	53.3	89.6
		Output Torque Nm	322	501	771	919	1593	2889	4062	5501	8343	12082	22943	39078
20	15	Input Power kW	0.9	1	1.5	2.1	2.8	5.7	7.9	10.7	19.2	29.5	42.8	75.1
		Output Torque Nm	390	478	733	1033	1899	3010	4046	5606	10696	16346	23626	41028
25	12	Input Power kW	0.7	1	1.8	1.9	2.9	4.6	7.2	9.7	18.8	24.1	33.9	66.3
		Output Torque Nm	371	675	828	1028	1771	2807	4513	6267	10684	18824	26666	37788
30	10	Input Power kW	0.5	0.9	1.3	1.5	2.8	4.4	6	7.9	13.5	21.5	30.7	53.9
		Output Torque Nm	342	667	867	1060	1928	3132	4371	6086	10268	16803	24900	43119
35	8.5	Input Power kW	-	-	-	1.5	2.5	3.9	5.3	-	-	17.2	-	-
		Output Torque Nm	-	-	-	1088	1962	3082	4361	-	-	18674	-	-
40	7.5	Input Power kW	0.4	0.8	1	1.3	2.2	3.6	5.1	6.7	11.9	18.7	26.9	36.3
		Output Torque Nm	309	506	796	1109	1838	2338	4707	6261	11271	18124	26037	38516
60	6	Input Power kW	0.3	0.6	0.7	1	1.8	3	4.5	6.9	10	15.2	21.6	40.8
		Output Torque Nm	272	470	700	990	1826	3124	4911	6966	11458	17777	28386	49925
90	5	Input Power kW	0.2	0.3	0.6	0.9	1.8	2.4	3.8	5	8.5	12	19.8	26
		Output Torque Nm	196	363	563	846	1850	2876	4486	6396	11267	17587	27648	37188
70	4.3	Input Power kW	0.2	0.2	0.4	0.6	1.1	1.9	2.9	4.2	7	11.2	16.6	27.8
		Output Torque Nm	177	276	427	740	1483	2529	3970	5906	10639	17306	28912	46233

Ratings Based on Input Speeds of 150 r.p.m.

Nom. Redn. Ratio	Nom. Output rpm	Capacity	Size of Unit											
			237	287	337	400	500	600	700	800	1000	1200	1400	1700
5	30	Input Power kW	0.9	1.3	2.6	3.1	5	9.3	12.5	17.2	30.1	45.2	63.3	-
		Output Torque Nm	258	371	687	827	1416	2579	3579	4937	8503	12961	18117	-
7.5	20	Input Power kW	0.7	1.1	1.7	2.1	4	6.1	9.7	12.7	21.1	32.9	44.4	-
		Output Torque Nm	260	427	667	868	1680	2566	4096	5406	8837	14016	19762	-
10	15	Input Power kW	0.6	0.9	1.4	1.9	3.8	5.2	7.3	9.5	14.6	25.2	35.6	74.8
		Output Torque Nm	292	463	732	995	1921	2830	3966	5176	8430	14602	19906	43814
12.5	12	Input Power kW	-	-	-	1.5	-	-	-	-	-	20.8	32.3	-
		Output Torque Nm	-	-	-	1028	-	-	-	-	-	14251	23207	-
15	10	Input Power kW	0.5	0.8	1.3	1.5	2.6	4.5	6.3	8.4	12.7	19	32.2	56.3
		Output Torque Nm	372	600	925	1108	1921	3496	4896	6665	10121	14682	27430	47814
20	7.5	Input Power kW	0.5	0.8	0.9	1.3	2.4	3.6	4.9	6.7	12	18.8	26.6	46.9
		Output Torque Nm	464	570	574	1237	2276	3620	4871	6760	12908	19762	29591	50773
25	6	Input Power kW	0.4	0.7	0.9	1.1	1.8	2.9	4.5	6.1	9.9	15.1	21.1	34.6
		Output Torque Nm	441	684	887	1226	2117	3361	5409	7504	12641	19088	27368	45710
30	5	Input Power kW	0.3	0.6	0.8	1	1.8	2.8	3.8	4.9	8.4	13.8	19.2	32.9
		Output Torque Nm	406	661	1031	1263	2301	3744	5235	7048	12316	20383	29968	52047
35	4.3	Input Power kW	-	-	-	0.9	1.6	2.6	3.4	-	-	10.8	-	-
		Output Torque Nm	-	-	-	1294	2326	3899	5203	-	-	16790	-	-
40	3.8	Input Power kW	3	0.4	0.6	0.9	1.4	2.3	3.2	4.3	7.5	11.8	16.3	21.6
		Output Torque Nm	398	686	843	1306	2185	3852	5611	7478	13606	21744	31280	43640
60	3	Input Power kW	0.2	0.3	0.5	0.7	1.2	1.9	2.8	3.8	6.3	9.7	13.8	25.7
		Output Torque Nm	288	506	826	1172	2195	3798	5836	7821	13716	21266	31083	59924
80	2.5	Input Power kW	0.1	0.2	0.3	0.5	1	1.5	2.3	3.2	5.4	8.3	12.5	19.6
		Output Torque Nm	307	372	594	886	2142	3390	5296	7597	13402	20983	32883	44488
70	2.1	Input Power kW	0.1	0.1	0.2	0.4	0.7	1.1	1.7	2.4	4.3	7.1	10.8	17.7
		Output Torque Nm	-	291	448	706	1528	2689	4176	6290	11934	20292	30888	54006

Ratings Based on Input Speeds of 100 r.p.m.

Nom. Ratio	Nom. Output rpm	Capacity	Size of Unit											
			237	287	337	400	500	600	700	800	1000	1200	1400	1700
5	20	Input Power kW	0.7	1	1.5	2.3	3.8	7	9.5	15	22.8	34.4	48.1	-
		Output Torque Nm	287	415	766	923	1583	2886	4869	5536	9555	14471	20415	-
7.5	13.3	Input Power kW	0.5	0.8	1.3	1.8	3	4.8	7.3	8.8	15.8	24.3	33.8	-
		Output Torque Nm	288	473	730	964	1847	2900	4360	6020	8875	15673	22113	-
10	10	Input Power kW	0.43	0.64	1.07	1.45	2.73	3.97	5.53	7.18	10.99	19.74	26.71	56.56
		Output Torque Nm	324	513	811	1093	2132	3150	4400	5750	8385	16278	22211	48854
12.5	8	Input Power kW	-	-	-	1.1	-	-	-	-	-	15.6	34.3	-
		Output Torque Nm	-	-	-	1088	-	-	-	-	-	15807	29038	-
15	6.7	Input Power kW	0.4	0.6	1	1.2	2	3.4	4.7	6.3	9.6	13.8	24.9	41.8
		Output Torque Nm	410	661	1021	1223	2126	3670	5424	7377	11236	16306	26882	52971
20	5	Input Power kW	0.4	0.5	0.7	1	1.8	2.7	3.7	5	9.1	14	20	35.3
		Output Torque Nm	511	627	863	1364	2513	3968	5387	7488	14291	21883	31888	56376
25	4	Input Power kW	0.32	0.48	0.7	0.96	1.38	2.17	3.29	4.57	7.45	11.38	15.9	25.27
		Output Torque Nm	485	753	1087	1331	2332	3707	5969	8283	14188	21227	30293	49178
30	3.3	Input Power kW	0.3	0.4	0.6	0.8	1.3	2.1	3.8	3.7	6.4	10.3	14.5	25.5
		Output Torque Nm	444	728	1133	1380	2534	4126	5774	7789	13098	22311	33120	57630
35	2.8	Input Power kW	-	-	-	0.7	1.2	1.9	2.4	-	-	7.8	-	-
		Output Torque Nm	-	-	-	1422	2576	4061	5733	-	-	20132	-	-
40	2.5	Input Power kW	0.2	0.3	0.5	0.7	1.1	1.7	2.5	3.3	5.7	8	12.4	19.3
		Output Torque Nm	388	635	1038	1433	2403	4236	6174	8237	13004	24004	34521	49152
50	2	Input Power kW	0.1	0.2	0.3	0.5	0.8	1.4	2.2	2.9	4.8	7.4	10.4	19.5
		Output Torque Nm	296	520	826	1285	2376	4071	6410	8601	13696	23430	34290	65145
60	1.7	Input Power kW	0.1	0.1	0.2	0.4	0.7	1.1	1.8	2.4	4.2	6.3	9.5	12.8
		Output Torque Nm	212	382	609	1024	2197	3478	5488	8257	14739	25106	38288	49053
70	1.4	Input Power kW	0.1	0.1	0.2	0.3	0.5	0.8	1.2	1.8	3.1	5	7.8	13.4
		Output Torque Nm	198	298	486	805	1585	2724	4277	6443	12223	20784	32918	59472

Ratings Based on Input Speeds of 50 r.p.m.

Nom. Ratio	Nom. Output rpm	Capacity	Size of Unit											
			237	287	337	400	500	600	700	800	1000	1200	1400	1700
5	10	Input Power kW	0.4	0.6	1.2	1.4	2.3	4.3	3.8	8	14.1	21.2	29.5	-
		Output Torque Nm	340	490	811	1099	1889	3450	4797	8633	11489	17427	24519	-
7.5	6.7	Input Power kW	0.3	0.5	0.9	1	1.8	2.8	4.5	5.8	9.7	15.1	20.9	-
		Output Torque Nm	338	558	863	1141	2188	3428	5423	7187	11773	18767	26419	-
10	5	Input Power kW	0.28	0.38	0.64	0.88	1.66	2.43	3.37	4.37	6.88	12.03	16.28	32.2
		Output Torque Nm	381	601	955	1289	2517	3723	5219	6823	11131	19336	28420	54412
12.5	4	Input Power kW	-	-	-	0.6	-	-	-	-	-	9.5	14.8	-
		Output Torque Nm	-	-	-	1138	-	-	-	-	-	18774	30738	-
15	3.3	Input Power kW	0.2	0.4	0.6	0.7	1.2	2.1	2.9	3.8	5.8	8.2	15.1	25.3
		Output Torque Nm	478	774	1189	1438	2486	4559	6385	8683	13207	19296	28048	62747
20	2.5	Input Power kW	0.2	0.3	0.4	0.8	1.1	1.8	3.3	3.1	5.9	8.5	12.2	21.5
		Output Torque Nm	598	725	1123	1595	2940	4679	8325	8769	18809	25785	37362	68592
25	2	Input Power kW	0.2	0.3	0.4	0.5	0.8	1.3	2.1	2.8	4.6	7	9.7	13.8
		Output Torque Nm	563	878	1287	1577	2890	4336	6988	9088	18640	24840	35637	51675
30	1.7	Input Power kW	0.2	0.3	0.4	0.5	0.8	1.3	1.8	2.1	3.8	6.2	8.9	15.6
		Output Torque Nm	515	843	1317	1618	2958	4820	6754	8321	15610	29182	38886	67792
35	1.4	Input Power kW	-	-	-	0.4	0.8	1.2	1.8	-	-	4.3	-	-
		Output Torque Nm	-	-	-	1054	2992	4738	6957	-	-	21021	-	-
40	1.3	Input Power kW	0.1	0.2	0.3	0.4	0.7	1.1	1.5	2	3.6	5.8	7.6	8.9
		Output Torque Nm	427	722	1188	1684	2798	4933	7197	9614	17338	29110	40647	47038
50	1	Input Power kW	0.1	0.1	0.2	0.3	0.6	0.8	1.3	1.8	3	4.8	6.5	12.1
		Output Torque Nm	307	540	889	1368	2698	4626	7452	10017	17905	27388	40112	77592
60	0.8	Input Power kW	0	0.1	0.1	0.2	0.4	0.6	0.9	1.4	2.5	4	5.8	7.8
		Output Torque Nm	220	395	631	1059	2276	3809	5658	8543	16333	29943	43239	57345
70	0.7	Input Power kW	0	0.1	0.1	0.1	0.3	0.4	0.7	1	1.7	2.8	4.3	7.5
		Output Torque Nm	188	307	475	831	1619	2811	4413	6649	12814	21440	33971	61896

Ratings Based on Input Speeds of 25 r.p.m.

Input Redn Ratio	How Output rpm	Capacity	Size of Unit											
			337	407	537	666	806	966	1166	1406	1706	2006	2306	
5	5	Input Power kW	0.2	0.4	0.7	0.8	1.4	2.3	3.9	4.8	8.3	11.7	16.2	-
		Output Torque Nm	397	573	1068	1290	2229	3851	5653	7922	13578	18796	26177	-
7.5	3.3	Input Power kW	0.2	0.5	0.4	0.6	1.1	1.7	2.5	3.5	5.5	8.6	12	-
		Output Torque Nm	385	651	1005	1331	2557	4010	6041	8395	13828	20829	30117	-
10	2.5	Input Power kW	0.2	0.3	0.4	0.5	1	1.4	2	2.6	4	7.2	9.8	17.4
		Output Torque Nm	441	696	1108	1501	2932	4342	6094	7972	13017	22644	30985	37364
12.5	2	Input Power kW	-	-	-	0.3	-	-	-	-	-	2.7	3.9	-
		Output Torque Nm	-	-	-	1193	-	-	-	-	-	21929	26925	-
15	1.7	Input Power kW	0.1	0.2	0.3	0.4	0.7	1.2	1.7	2.3	3.3	4.8	6.5	14.3
		Output Torque Nm	552	894	1304	1665	2909	5293	7423	10116	15458	22489	30125	49029
20	1.3	Input Power kW	0.1	0.2	0.2	0.4	0.6	1	1.4	1.8	3.3	4.5	7	12.7
		Output Torque Nm	486	755	1209	1644	3408	5414	7325	10171	15520	23994	41478	76311
25	1	Input Power kW	0.1	0.2	0.3	0.3	0.8	0.8	1.2	1.7	2.7	4.2	5.9	7.4
		Output Torque Nm	448	1008	1460	1829	2793	5011	7544	11085	16278	26037	41291	62668
30	0.8	Input Power kW	0.1	0.2	0.2	0.2	0.4	0.6	1.1	1.1	2.1	3.5	4.9	9.9
		Output Torque Nm	501	908	1516	1886	3023	5569	7667	10113	16157	26428	41668	78733
35	0.7	Input Power kW	-	-	-	0.28	0.42	0.69	0.97	-	-	2.22	-	-
		Output Torque Nm	-	-	-	1904	3277	5461	7733	-	-	21687	-	-
40	0.6	Input Power kW	0.1	0.1	0.2	0.2	0.4	0.6	0.9	1.2	2.1	3.4	4.7	4.4
		Output Torque Nm	438	744	1268	1912	3222	5679	8293	11093	20298	32522	46815	48418
50	0.5	Input Power kW	0	0.1	0.1	0.2	0.3	0.5	0.7	1.1	1.6	2.8	4	7.5
		Output Torque Nm	318	554	911	1401	2788	4744	7733	11180	20295	31626	46357	89862
60	0.4	Input Power kW	0	0	0.1	0.1	0.2	0.3	0.5	0.7	1.3	2.3	3.5	4.8
		Output Torque Nm	225	494	845	1093	2324	3679	5785	8730	16699	28003	43999	82344
70	0.4	Input Power kW	0	0	0	0.1	0.1	0.2	0.4	0.5	0.9	1.5	2.4	4.7
		Output Torque Nm	209	313	484	848	1647	2966	4580	6760	12962	21871	34029	62114

RATINGS OF GEARBOX FOR GATE APPLICATION AT INPUT SPEED 1500 R.P.M.

Gear Ratio	Output Speed R.P.M.	Capacity	Size of Unit				
			400	500	600	700	800
50:1	30	Input Power kW	3.4	3.3	6.6	12.8	11.5
		Output Torque Nm	766	1291	3099	3229	4440
60:1	25	Input Power kW	2.9	4.3	7.1	10.8	13.8
		Output Torque Nm	742	1171	2039	3196	4019

RATINGS OF GEARBOX FOR GATE APPLICATION AT INPUT SPEED 1000 R.P.M.

Gear Ratio	Output Speed R.P.M.	Capacity	Size of Unit				
			400	500	600	700	800
50:1	20	Input Power kW	2.8	4.5	6.9	9.6	13.9
		Output Torque Nm	920	1544	2428	3030	4965
60:1	16.7	Input Power kW	2.5	3.7	5.4	8	11
		Output Torque Nm	698	1483	2054	3424	4739

Ratings of Gearbox for Gate Application at Input Speed 1500 R.P.M.

Gear Ratio	Output Speed R.P.M.	Capacity	Size Of Unit				
			400	500	600	700	800
50/1	30	Input Power KW	3.4	5.3	8.5	12.8	17.5
		Output Torque Nm	768	1261	2089	3229	4440
60/1	25	Input Power KW	2.8	4.2	7.1	10.9	13.5
		Output Torque Nm	742	1171	2033	3195	4013

Ratings of Gearbox for Gate Application at Input Speed 1000 R.P.M.

Gear Ratio	Output Speed R.P.M.	Capacity	Size Of Unit				
			400	500	600	700	800
50/1	20	Input Power KW	2.8	4.5	6.8	9.6	13.5
		Output Torque Nm	920	1544	2428	3530	4966
60/1	16.7	Input Power KW	2.5	3.7	5.4	8	11
		Output Torque Nm	939	1483	2254	3424	4728

Exact Standard Gear Ratios Single Reduction Units

Nominal Ratio	Size of Unit														
	112	162	200	237	287	337	400	500	600	700	800	1000	1200	1400	1700
5/1	5.25	5.25	4.8	5.0	5.2	4.83	4.83	5.0	4.88	5.0	5.0	4.89	4.9	4.91	-
7.5/1	-	7.33	7.33	7.33	7.25	7.25	7.5	7.4	7.6	7.5	7.5	7.33	7.43	7.71	-
10/1	10.5	10.5	10.5	9.67	10.33	9.67	9.67	9.75	9.75	9.75	9.75	10.25	9.8	9.8	10.17
12.5/1	-	-	-	-	-	-	12.75	-	-	-	-	-	12.25	12.75	-
15/1	14.5	14.5	14.5	15.0	14.5	14.5	14.5	14.5	14.67	14.67	14.67	14.67	14.67	14.75	15.25
20/1	20	19.5	20	20	19.5	19.5	19.5	19.5	20	19.5	19.5	20.5	19.67	19.67	19.67
25/1	25	25	25	25	25	25	25	24.5	24.5	24.5	24.5	25.5	24.5	24.5	24.67
30/1	30	30	30	30	30	30	30	30	30	30	29.5	29.5	29.5	30.5	29.5
35/1	-	-	-	-	-	-	-	35	35	35	-	-	35.5	-	-
40/1	40	40	40	40	40	40	40	40	40	40	40	40	40	40	40.5
50/1	50	50	50	50	50	50	50	50	50	50	50	50	50	50	50
60/1	60	60	60	60	60	60	60	60	60	60	60	60	60	60	60
70/1	70	70	70	70	70	70	70	70	70	70	70	70	70	70	70



Direction of rotation

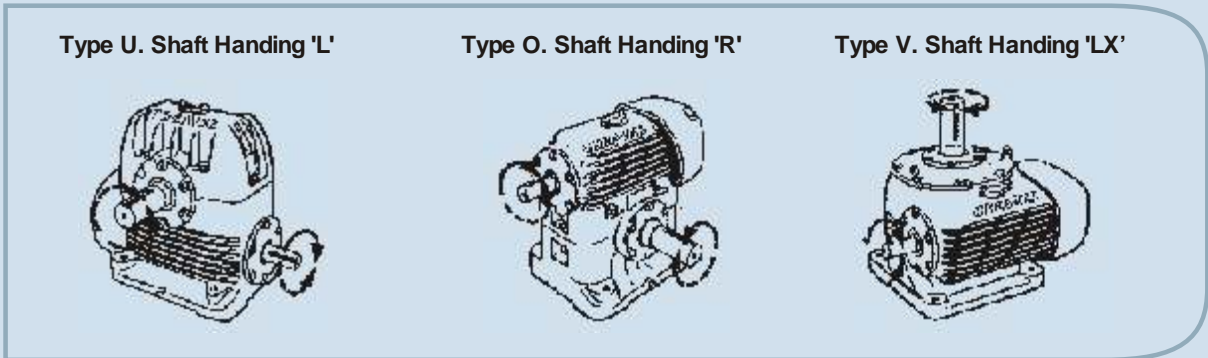

Double Reduction Speed Reducers Ratings Types: AUD-AOD-AVD

Nominal Ratio	Nominal Input	Nominal Output Speed r.p.m.	SIZE OF UNIT									
			162		200		237		287		337	
			Input KW	Output Torque Nm	Input KW	Output Torque Nm	Input KW	Output Torque Nm	Input KW	Output Torque Nm	Input KW	Output Torque Nm
100/1	750	7.50	0.12	103.98	0.29	223.67	0.46	369.84	0.53	481.67	0.80	735.75
	1000	10.0	0.15	97.90	0.36	210.91	0.52	321.77	0.65	454.20	0.94	670.02
	1500	15.0	0.21	89.37	0.43	172.65	0.56	23.40	0.87	413.00	1.06	509.14
150/1	750	5.00	0.11	111.83	0.18	199.14	0.30	316.86	0.44	539.55	0.67	837.77
	1000	6.67	0.14	105.95	0.23	189.33	0.37	300.18	0.54	511.10	0.82	792.65
	1500	10.0	0.18	97.22	0.30	173.64	0.50	266.83	0.73	467.94	1.03	690.62
200/1	750	3.75	0.08	96.33	0.12	177.56	0.21	274.68	0.30	466.95	0.47	730.84
	1000	5.00	0.10	91.72	0.17	168.73	0.26	260.94	0.38	443.41	0.58	693.57
	1500	7.50	0.14	84.85	0.23	155.98	0.36	241.32	0.51	409.08	0.78	638.63
300/1	750	2.50	0.07	122.62	0.15	267.81	0.24	442.43	0.27	576.83	0.41	887.80
	1000	3.33	0.09	117.72	0.18	256.04	0.30	422.81	0.33	551.32	0.51	842.68
	1500	5.00	0.12	109.87	0.26	238.38	0.41	393.38	0.46	513.06	0.56	626.86
400/1	750	1.88	0.07	135.38	0.09	173.64	0.18	406.13	0.21	560.15	0.21	525.81
	1000	2.50	0.09	135.38	0.10	160.88	0.21	390.44	0.26	518.95	0.26	487.56
	1500	3.75	0.12	135.38	0.12	143.22	0.30	367.87	0.32	435.56	0.32	409.08
600/1	750	1.25	0.06	135.38	0.09	230.53	0.12	434.58	0.18	653.34	0.21	739.67
	1000	2.67	0.07	135.38	0.10	214.84	0.17	418.89	0.24	653.34	0.26	687.68
	1500	2.50	0.10	135.38	0.12	190.31	0.24	394.36	0.32	574.86	0.32	577.81
750/1	750	1.00	0.04	101.04	0.06	178.54	0.09	283.51	0.12	495.40	0.18	742.62
	1000	1.33	0.04	96.43	0.07	170.69	0.11	271.74	0.15	472.84	0.23	708.28
	1500	2.00	0.07	90.45	0.10	159.90	0.15	253.10	0.21	440.47	0.30	659.23
1000/1	750	0.75	0.04	135.38	0.08	296.26	0.11	489.52	0.14	654.33	0.21	1059.00
	1000	1.00	0.05	135.38	0.10	285.47	0.14	470.88	0.18	654.33	0.26	990.81
	1500	1.50	0.08	135.38	0.12	259.96	0.18	442.43	0.24	654.33	0.32	839.73
1200/1	750	0.63	0.04	135.38	0.07	272.72	0.10	437.52	0.12	654.33	0.20	1128.00
	1000	0.83	0.05	135.38	0.08	262.91	0.12	420.85	0.15	654.33	0.24	1128.00
	1500	1.25	0.07	135.38	0.11	248.19	0.15	396.32	0.21	654.33	0.32	981.00
2000/1	750	0.38	0.01	114.78	0.04	205.03	0.05	327.65	0.07	572.90	0.11	864.26
	1000	0.50	0.03	110.85	0.05	197.18	0.07	315.88	0.10	552.30	0.12	831.89
	1500	0.75	0.04	105.95	0.07	186.39	0.10	298.22	0.12	519.93	0.18	781.86
2800/1	750	0.27	0.01	101.04	0.03	176.58	0.04	287.43	0.06	480.69	0.08	746.54
	1000	0.36	0.01	97.90	0.04	170.69	0.05	277.62	0.07	464.01	0.10	719.07
	1500	0.54	0.04	92.90	0.05	161.86	0.07	261.93	0.10	437.52	0.14	676.89

Nominal ratios listed are a typical selection of commonly used ratios from the overall range. Details of other ratios available on request.

Direction of rotation



Double Reduction Premium Speed Reducers Ratings Types: UD-OD-VD

Nominal Ratio	Nominal Input Speed r.p.m.	Nominal Output Speed r.p.m.	SIZE OF UNIT									
			400		500		600		700		800	
			Input KW	Output Torque Nm	Input KW	Output Torque Nm	Input KW	Output Torque Nm	Input KW	Output Torque Nm	Input KW	Output Torque Nm
150/1	750	5.00	0.83	972.17	1,53	1805	2,24	2864	3.15	4061	4.29	5709
	1000	6.66	1.07	931.95	1.94	1736	2.76	2737	3.95	3894	5.44	5572
	1500	10.0	1.42	883.88	2.53	15.99	3.65	2531	5.15	3482	7.17	5013
300/1	750	2.50	0.65	1157	1.00	2001	1.45	3345	2.01	4512	2.83	6779
	1000	3.33	0.82	1108	1.31	1913	1.71	3159	2.39	4238	3.43	6386
	1500	5.00	1.04	1000	1.77	1717	2.31	2874	3.21	3924	4.55	5758
500/1	750	1.50	0.46	1255	0.74	2236	1.04	3345	1.42	5140	1.64	6210
	1000	2.00	0.57	1206	0.97	2236	1.24	3345	1.79	4885	2.16	6210
	1500	3.00	0.74	1128	1.28	2080	1.71	3227	2.39	4512	3.13	6210
1000/1	750	0.75	0.30	1275	0.46	2197	0.65	3453	0.89	5140	1.12	6779
	1000	1.00	0.36	1236	0.57	2138	0.74	3384	1.12	5140	1.42	6779
	1500	1.50	0.48	1177	0.74	2030	1.06	3335	1.64	5140	2.01	6661
2000/1	750	0.38	0.19	1275	0.33	2246	0.35	3119	0.55	5199	0.74	7112
	1000	0.50	0.24	1236	0.41	2168	0.45	3119	0.67	5199	0.97	7112
	1500	0.75	0.32	1206	0.54	2109	0.61	3119	0.97	5199	1.27	7112
3000/1	750	0.25	0.12	1089	0.24	2374	0.27	2864	0.46	5307	0.59	7455
	1000	0.33	0.15	1089	0.30	2286	0.36	2864	0.56	5307	0.74	7455
	1500	0.50	0.21	1089	0.39	2109	0.48	2864	0.74	5307	1.04	7112

Nominal ratios listed are a typical selection of commonly used ratios from the overall range.
 Details of other ratios available on request.



Direction of rotation

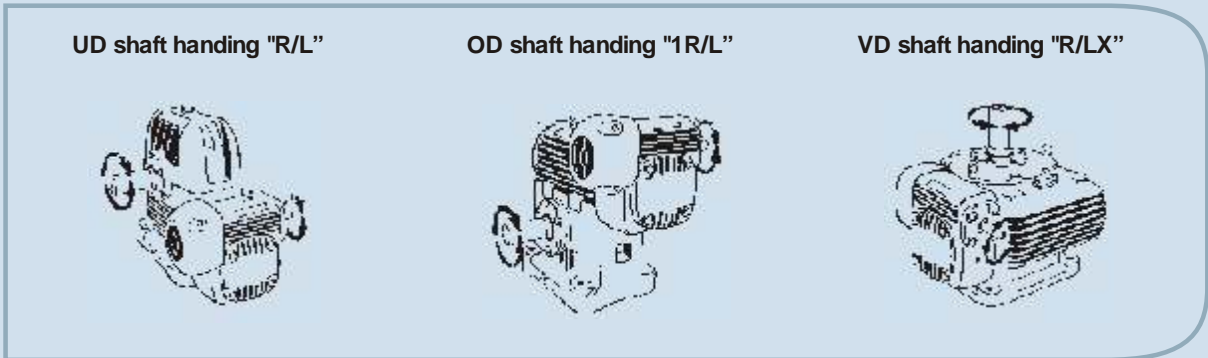

Double Reduction Speed Reducers Ratings Types: UD-OD-VD

Nominal Ratio	Nominal Input Speed r.p.m.	Nominal Output Speed r.p.m.	SIZE OF UNIT							
			1000		1200		1400		1700	
			Input KW	Output Torque Nm	Input KW	Output Torque Nm	Input KW	Output Torque Nm	Input KW	Output Torque Nm
150/1	750	5.00	7.46	10055	10.44	15931	13.4	19659	23.87	38426
	1000	6.66	8.95	1378	12.68	14921	17.16	18874	30.58	36728
	1500	10.0	11.19	8191	16.41	12998	23.12	17403	41.03	33903
300/1	750	2.50	4.32	10791	5.52	14803	9.70	25427	15.66	42948
	1000	3.33	5.44	10281	6.93	14126	11.93	24074	20.14	41251
	1500	5.00	7.01	9211	8.95	12939	15.66	21238	26.85	37288
500/1	750	1.50	2.91	11870	3.58	14401	5.15	21474	9.70	40682
	1000	2.00	3.58	11242	4.69	14401	6.79	21474	12.68	40682
	1500	3.00	4.85	10055	6.86	14401	9.70	21474	17.90	40682
1000/1	750	0.75	1.64	10173	2.76	19433	3.80	25535	6.12	45773
	1000	1.00	2.16	10173	3.50	19041	4.55	25535	7.46	45773
	1500	1.50	3.13	10173	4.84	18080	6.64	25535	11.19	45773
2000/1	750	0.38	0.82	11634	1.56	19208	2.24	27124	3.88	50286
	1000	0.50	1.04	11634	2.01	19208	2.83	27124	5.15	50286
	1500	0.75	1.56	11634	2.90	19208	4.10	27124	7.46	50286
3000/1	750	0.25	0.74	11075	1.11	17403	1.56	25761	2.61	46332
	1000	0.33	0.97	11075	1.49	17403	2.01	25761	3.36	46332
	1500	0.50	1.42	1075	2.16	17403	2.91	25761	4.70	46332

Nominal ratios listed are a typical selection of commonly used ratios from the overall range. Details of other ratios available on request.

Heliworm Speed Reducers Ratings Types : BSU-BSO-BSV

Nominal Ratio	Nominal Input Speed r.p.m.	Nominal Output Speed r.p.m.	SIZE OF UNIT															
			400		500		600		700		800		1000		1200		1400	
			Input KW	Output Torque Nm	Input KW	Output Torque Nm	Input KW	Output Torque Nm	Input KW	Output Torque Nm	Input KW	Output Torque Nm	Input KW	Output Torque Nm	Input KW	Output Torque Nm	Input KW	Output Torque Nm
80/1	750	9.38	1.21	903.7	2.14	1683	3.32	2628	4.37	3524	5.67	4710	6.38	5648	10.44	8472	15.89	13555
	1000	12.50	1.48	847.2	2.62	1570	4.06	2530	5.34	3321	6.79	4439	8.20	5479	12.31	8077	20.14	12991
	1500	18.75	1.92	746.7	3.19	1299	5.27	2236	6.73	2903	9.55	4100	11.41	5196	16.11	7229	26.85	11861
100/1	750	7.50	1.008	81.1	1.52	1423	2.46	2440	3.74	3750	5.00	5083	5.33	5648	7.87	8472	13.43	14233
	1000	10.00	1.198	13.3	1.93	1378	3.17	2304	4.77	3682	6.26	4857	6.86	5535	10.26	8077	16.71	13104
	1500	15.00	1.527	11.6	2.59	1265	4.04	2033	6.39	3344	8.13	4292	9.51	5219	13.35	7229	20.44	10844
120/1	750	6.25	0.89	903.7	1.36	1649	2.36	2598	3.18	3660	4.03	4744	4.77	5648	6.86	8472	10.52	13329
	1000	8.33	1.07	847.2	1.92	1559	2.97	2485	4.01	3502	5.07	4518	6.04	5535	8.59	8077	12.90	12426
	1500	12.05	1.41	756.8	2.46	1389	3.86	2259	5.25	3140	6.79	4157	8.35	5219	11.11	7229	16.26	10618
160/1	750	4.69	0.72	915.0	1.20	1525	1.98	2711	2.65	3841	3.39	4970	3.88	5648	5.63	8472	9.99	15363
	1000	6.25	0.89	869.8	1.48	1446	2.43	2575	3.29	3660	4.21	4801	4.96	5535	6.94	8077	11.7	13781
	1500	9.36	1.17	790.7	1.92	1310	3.15	2327	4.37	3344	5.78	4383	6.79	5219	9.06	7229	13.05	10618
200/1	750	3.75	0.55	790.7	0.98	1468	1.53	2553	2.20	3795	3.03	5253	3.17	5648	4.68	8472	7.46	13555
	1000	5.00	0.68	756.8	1.21	1401	1.95	2429	2.74	3660	3.77	5027	4.03	5535	5.80	8077	9.32	13104
	1500	7.50	0.89	689.1	1.56	1276	2.53	2214	3.67	3366	4.92	4575	5.44	5219	7.44	7229	12.38	11861
240/1	750	3.13	0.41	677.8	0.84	1468	1.24	2270	1.83	3569	2.55	5027	2.77	5648	4.03	8472	6.49	13555
	1000	4.17	0.55	711.6	0.97	1310	1.54	2169	2.15	3231	3.16	4801	3.50	5535	5.07	8077	7.91	12878
	1500	6.25	0.72	655.2	1.26	1209	1.97	1920	2.65	2790	4.14	4383	4.81	5219	6.53	7229	10.44	11861
Output Torque For Standard Shafts	Normal Overload		960.2 1920		1355 2711		2203 4405		2937 5874		3841 7681		5648 11296		8811 17622		15815 31629	

Exact Ratios ** - BSU-BSO-BSV

Nominal Ratio	SIZE OF UNIT							
	400	500	600	700	800	1000	1200	1400
80/1	78.00	78.00	81.25	81.44	81.44	85.42	81.96	79.72
100/1	100.00	98.00	99.53	102.32	102.32	106.25	102.08	99.29
120/1	120.00	120.00	121.88	125.29	123.20	122.92	122.92	123.61
160/1	160.00	160.00	162.50	167.06	167.06	166.67	166.70	162.11
200/1	200.00	200.00	203.13	208.82	208.82	208.33	208.33	202.63
240/1	240.00	240.00	243.75	250.59	250.59	250.00	250.00	243.16

If the ACTUAL output torque required exceeds the figure shown in bold type at the foot of the table consideration should be given to the use of additional keys etc. in the output shaft. **Ratios, Inputs Speeds and Output Speeds are nominal. Exact equivalent standard ratios are listed below.

Direction of rotation

BSU shaft handing "1/L"

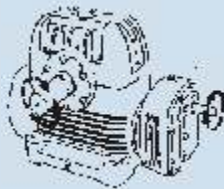

BSU shaft handing "3/L"

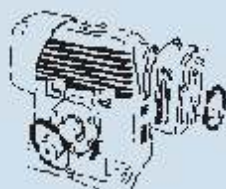

BSV shaft handing "1/LX"

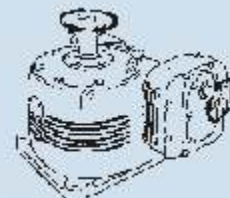



Overhung Loads Single Reduction Units

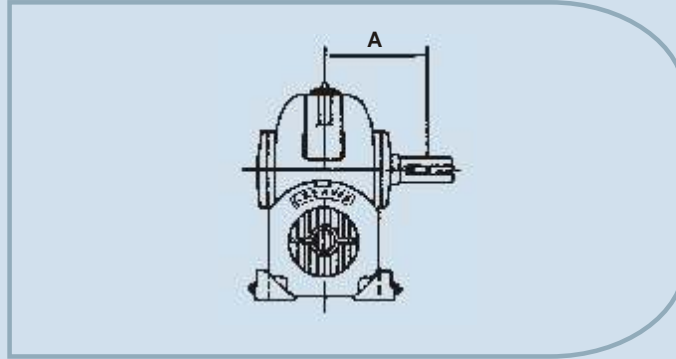

Premium speed reducers are fitted with taper roller bearings of generous proportions which in addition to accommodating normal loads imposed by the worm gears, have an ample margin for taking overhung loads. In cases where external loads are applied in excess of this margin, wider taper roller bearings and wheel shafts of high tensile material can be fitted without any alteration to standard units, Whenever a sprocket, gear, sheave or pulley is mounted on the output shaft, a calculation should be made to determine the overhung load in Newtons on the shaft, using the formula :

$$P = \frac{KW \times 9.550,000 \times K}{N \times R}$$

Where, P = equivalent overhung load in Newtons

KW = power carried by shaft in Kilo Watts

N = r.p.m, of the shaft

R = pitch radius of sprocket, pinion, sheave or pulley in mm

K = factor

Overhung Member	K Factor
Sprocket, Single Strand	1.00
Spur Pinion	1.25
V-belt Sheave	1.50
Flat Belt Pulley	2.00

The calculated equivalent overhung load should be compared with the permissible values given in the table. These tabulated values are based on an input speed of 1500 rpm, with the unit transmitting full rated power and the direction of overhung load in the most unfavourable direction. Hence they can sometimes be increased for lesser input speed, or if the power transmitted is less than the rated capacity of the gear unit, or if the load is applied nearer to the gear unit case, or if the direction of load is more favourable. In any event the sprocket, gear etc., should be positioned as close as possible to the gear unit case in order to reduce bearing loads and shaft stresses and to prolong life.



Maximum Permissible Overhung Loads (newtons) at centre of wheel shaft extension at 1,500 R.P.M. Input Speed.

Size Unit	Distance A (mm)	Type of bearing/ Wheelshaft Material	Nominal Ratio												
			5/1	7.5/1	10/1	12.5/1	15/1	20/1	25/1	30/1	35/1	40/1	50/1	60/1	70/1
112	62	Standard	801	-	1060	-	1070	1060	1060	1060	-	1070	1050	1000	935
162	75	Standard	2780	2750	2640	-	2530	2590	2440	2430	-	2510	2610	2720	2770
200	89	Standard	4400	4380	4180	-	4120	3900	3910	3960	-	4030	4150	4320	4430
237	105	Standard	5630	5610	5520	-	5290	4920	4940	5080	-	5210	5320	5480	5620
287	127	Standard	5030	4830	4640	-	3890	3990	3100	3170	-	3620	3890	4310	4790
337	151	Standard	9120	9520	9330	-	8720	8810	8370	8170	-	8470	8820	9020	9400
400	171	Standard WTR + HTS	11500 12800	12600 15100	12300 16500	12100 17600	12000 18700	11600 19800	11600 19800	11400 19700	-	11200 19600	11700 19900	11700 19900	11800 20000
500	197	Standard WTR + HTS	14500 20300	16600 23200	17800 25500	-	17800 29500	16800 29100	17100 29300	16500 28800	16400 28900	16900 29200	16900 29200	16700 29100	17300 29400
600	216	Standard WTR + HTS	15000 22000	18600 26600	19400 29400	-	17400 32100	16800 31700	17600 32100	16200 31400	16200 31400	15500 31100	16000 31300	17100 31900	17600 32200
700	235	Standard WTR + HTS	17400 21900	20800 25800	24200 29600	-	25300 33500	25200 37400	23500 39800	23900 42700	24100 44100	22600 43300	21500 42700	23300 43700	24600 44400
800	241	Standard WTR + HTS	17400 25000	21300 29800	25700 34900	-	28700 39400	28200 43900	25200 46800	26800 50700	-	25000 51000	23300 50200	23900 50500	26500 51800
1000	298	Standard WTR + HTS	19500 29900	24700 36400	30100 42800	-	32900 48700	30100 52300	30900 57000	30200 60200	-	29800 60000	29100 59700	28900 59600	25500 58000
1200	327	Standard WTR + HTS	24600 37000	29700 43700	36200 51300	40400 57500	39700 61700	35000 65200	34500 72500	31700 73700	29600 72900	32300 74000	32000 73900	34600 75100	25800 71400
1400	387	Standard WTR + HTS	41900 76100	48900 87400	57300 99100	61900 10700	64000 111000	73000 124000	81600 136000	85100 144000	-	88500 151000	88500 151000	85100 149000	87400 151000
1700	445	Standard WTR + HTS	-	-	58200 126000	-	71800 148000	81900 165000	94200 182000	98600 192000	-	11400 213000	118000 212000	122000 211000	125000 213000

WTR = Wider Taper Roller Bearing.

HTS = High Tensile Steel.

Above ratings are based on least of the thermal and mechanical output torque ratings with service factor one.



PREMIUM

Premium Energy Transmission Limited

Head Office : PB No. 5, Chinchwad , Pune - 411 019, India.
Tel. : (91-20)27475141/42/43/44 Fax : (91-20)27450287,27476601.
Website : www.premiumtransmission.com

Branch Offices :

Western Region :

Mumbai : Industry Manor, Appasaheb Marathe Marg, Prabhadevi , Mumbai - 400 025.
Tel. : (91-22)24223747,24365510, Fax : (91-22)24377730.

Ahmedabad : "Jaldarshan", Ashram Road , Navrangpura , Ahmedabad - 380 009.
Tel. : (91-79)26580428/0518/1861 Fax : (91-79)26587783.

Nagpur : "Guman", Pandit Jawaharlal Nehru Marg, Sadar, P.B. No. 129, Nagpur - 440 001.
Tel. : (91-712)2526588,2524125,2526038, Fax : (91-712)2541142.

Northern Region :

New Delhi : Express Building Annexe , 9-10, Bahadur Shah Zafar Marg, New Delhi - 110 002.
Tel. : (91-11)23730554(8 lines), Fax : (91-11)23359782.

Eastern Region :

Kolkata : Thapar House, 25, Brabourne Road , P.B. No. 702, Kolkata - 700 001.
Tel. : (91-33)22423811,22423780,22423805, Fax : (91-33)22424325.

Ranchi : Rani Kuthi, 82, Burdwan Compound , P.B. No. 139, Ranchi - 834 001.
Tel. : (91-651)2562651, Fax : (91-651)2562027.

Southern Region :

Chennai : "Wavoo Mansion", 6th Floor, New No. 48, (Old No. 39), Rajaji Salai, Chennai - 600 001.
Tel. : (91-44)25240142, Fax : (91-44)25224557.

Bangalore : 16/3, Ali Asker Road , P.B. No. 216, Bangalore - 560 052.
Tel. : (91-80)22268773/2506, Fax : (91-80)22253472.

Hyderabad : 6-2-47, A. C. Guards , 1st floor, P.B. No. 9, Hyderabad - 500 004.
Tel. : (91-40)23314025,23390544,23316446, Fax : (91-40)23318557.

Kochi : 39/5567, M. G. Road , Ernakulam, Kochi - 682 015.
Tel. : (91-484)2359190,2359372, Telefax : (91-484)2359589.

STARTING EFFICIENCIES

Gear box Size	Normal Ratio	REVERSIBLE									NON REVERSIBLE (SELF LOCKING)			
		5/1	7.5/1	10/1	12.5/1	15/1	20/1	25/1	30/1	35/1	40/1	50/1	60/1	70/1
112	Forward starting efficiency %	89	81	86	75	74	91	88	86	-	20	20	24	20
	Reverse starting efficiency %	88	84	88	18	18	0	0	0	-	0	0	0	0
132	Forward starting efficiency %	89	85	88	77	75	94	91	88	-	30	32	28	20
	Reverse starting efficiency %	87	84	86	21	21	0	0	0	-	0	0	0	0
164	Forward starting efficiency %	89	88	89	87	84	93	92	90	-	38	34	28	28
	Reverse starting efficiency %	84	84	84	31	22	18	0	0	-	0	0	0	0
200	Forward starting efficiency %	71	87	89	88	88	93	92	91	-	58	54	52	50
	Reverse starting efficiency %	70	82	84	35	38	0	0	0	-	0	0	0	0
237	Forward starting efficiency %	71	88	89	88	88	94	94	91	-	61	54	52	50
	Reverse starting efficiency %	70	87	86	40	24	0	0	0	-	0	0	0	0
287	Forward starting efficiency %	73	77	89	89	89	98	94	93	-	69	53	58	52
	Reverse starting efficiency %	72	88	89	48	44	32	0	0	-	0	0	0	0
337	Forward starting efficiency %	74	77	89	87	82	98	98	95	-	61	58	55	50
	Reverse starting efficiency %	74	88	89	58	44	12	0	0	-	0	0	0	0
400	Forward starting efficiency %	77	74	79	88	82	98	94	97	93	62	58	58	54
	Reverse starting efficiency %	75	88	89	64	54	11	0	0	-	0	0	0	0
499	Forward starting efficiency %	77	79	77	88	88	82	97	96	97	62	60	57	58
	Reverse starting efficiency %	76	72	88	59	58	43	30	0	-	0	0	0	0
600	Forward starting efficiency %	78	79	72	79	88	84	97	97	99	67	62	60	58
	Reverse starting efficiency %	76	72	88	64	57	48	38	12	-	0	0	0	0
799	Forward starting efficiency %	79	88	72	79	88	82	98	93	98	68	66	63	57
	Reverse starting efficiency %	76	72	88	62	58	43	38	12	-	0	0	0	0
888	Forward starting efficiency %	78	88	73	72	78	88	82	97	93	68	64	62	57
	Reverse starting efficiency %	76	79	89	60	58	56	44	26	-	0	0	0	0
1000	Forward starting efficiency %	78	78	75	-	79	87	82	98	-	69	67	62	-
	Reverse starting efficiency %	76	75	72	-	84	67	44	33	-	12	0	0	-
1200	Forward starting efficiency %	-	78	75	-	72	88	84	91	-	62	64	64	-
	Reverse starting efficiency %	-	78	72	-	87	58	47	30	-	18	0	0	-
1600	Forward starting efficiency %	-	78	76	-	72	88	86	91	-	62	64	67	-
	Reverse starting efficiency %	-	75	74	-	88	58	38	33	-	18	0	0	-
1700	Forward starting efficiency %	78	88	78	75	72	79	87	82	82	68	61	67	64
	Reverse starting efficiency %	78	88	73	71	88	68	38	38	32	0	0	0	0

Note :

1. Because of variations in the coefficient of friction which are due to differing conditions of materials, surface finish, lubricants etc., these efficiencies should be regarded as approximate and could vary a few percent either way. The above efficiencies are based on current stock ratios.
2. The gears indicated as being "reversible" are capable of being driven from the wormwheel at all speeds including from rest. If the application requires the wormwheel to be the driving member for any length of time it is preferable to choose a ratio well to the left of the line to obtain a high reverse efficiency.
3. Gears indicated as being "not reversible" are self locking only when at rest and provided that no vibrations are present i.e. as from adjacent working machinery.
4. Gears between the two lines can not safely be considered as being either reversible or non reversible. If reversibility or non reversibility is specifically required gears to the left or right of the respective lines should be selected.
5. Due to gears of sizes higher than 17 being made, wherever possible, to suit application, it is not possible to provide any specific starting efficiencies. If approximate ones are required full details of the application should be supplied.
6. The term "reversible" is used here to mean that the wormwheel is driving the wormshaft.