

PEMBRIL CONSTANT FILLING FLUID COUPLINGS

TYPE FCU Sizes 8 to 41

The type FCU fluid coupling when used in conjunction with a fixed-speed motor will give the motor a light-load start, provide smooth acceleration and ensure overload protection for the motor and driven machine. Using a fluid coupling in the drive-line often makes it possible to employ a smaller motor, because the fluid coupling will allow the motor to run quickly up to speed, where its overload capacity may be used for starting the machine.

Starting or stalling torque may be determined precisely by selection of the initial oil filling. Further adjustment, to suit drive requirements, may easily be made at site. The type FCU fluid coupling is a compact, rugged unit, the major components being aluminium alloy castings. It comprises the basic fluid coupling, diaphragm input mounting and multidisc type semi-flexible coupling on the output side. Bores and keyways may be finished to suit customer's requirements.

Fusible plugs are fitted to all except the smaller model fluid couplings to provide protection against excess temperature rise should the motor overload trip fail to operate during stall or overload conditions. Vertical applications can be catered for in most sizes.

Units are available in sixteen sizes, covering ratings from 0.1 kW to 1000kW. See selection chart overleaf.

Some of the typical applications include :-

- Belt Conveyors
- Barking Drums
- Chain Conveyors
- Hammer Mills
- Mixers and Agitators
- Rotary Dryers
- Crushers
- Centrifuges
- Haulages
- Reciprocating Pumps
- Ball Mills
- Marine Transmission
- Cranes



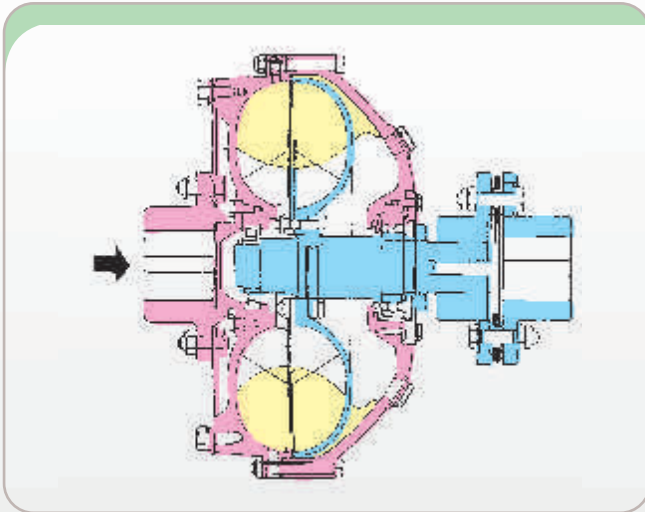

PEMBRIL CONSTANT FILLING FLUID COUPLINGS

TYPE FCU Sizes 8 to 41

SELECTION DATA

TYPE FCU SELECTION TABLE				
Size	Max. operating kW rating at various motor speeds.			
	580	720	960	1450
8	-	0.29	0.69	2.36
9.25	0.31	0.60	1.42	4.88
10.5	0.59	1.13	2.68	9.21
11.5	0.96	1.83	4.35	14.01
12.75	1.64	3.13	7.53	26.10
14.5	3.0	5.67	13.42	46.20
16.25	5.44	10.44	24.76	75.00
17.75	8.13	15.51	37.29	120.00
20	15.73	30.13	75.00	151.00
23	30.00	56.70	130.00	275.00
26	58.20	112.00	210.00	455.00
29	101.00	187.00	340.00	615.00
32	155.00	271.00	420.00	837.00
36	273.00	345.00	725.00	--

The above chart may be used for selecting a type FCU fluid coupling. It shows maximum operating power ratings for approved application with direct-on started squirrel cage motors, and will allow 200% full load torque for starting. Selections may be different from those shown, for drives having frequent cyclic duty, very high inertia starting, or diesel engine drives, such cases should be referred to Premium Energy Transmission Ltd. office or representative who will prepare specific proposals. These ratings are also generally suitable for drives employing slip-ring motors; for drives using DC motors consult Premium Energy Transmission Ltd. Allow for 3% to 5% slip in fluid coupling - low to high loadings.

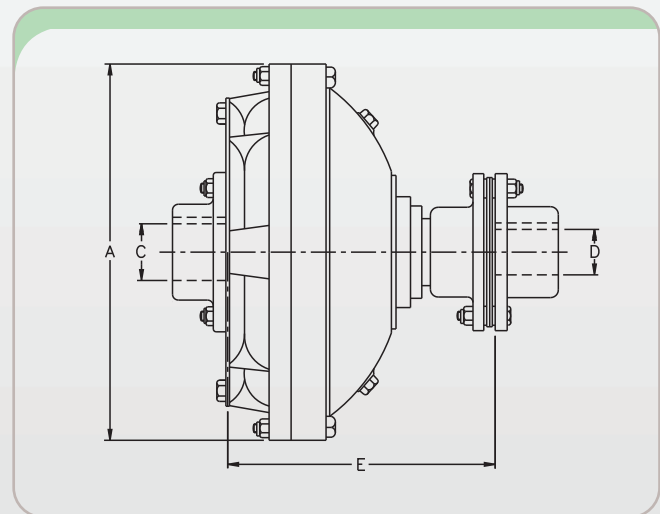

TECHNICAL DATA

Dimensions in mm							
Size	A	C	D	E	Filled Weight (Kgs)	GD2-PRI (Kg m ²)	Oil Qty Ltr.
8	237	42	35	165	13.2	0.246	1.7
9.25	268	48	48	194	17.7	0.332	2.6
10.5	308	48	48	210	22.2	0.54	3.7
11.5	333	60	55	232	35	0.75	4.6
12.75	368	60	55	262	41	1.38	6.8
14.5	419	80	70	287	57.6	2.53	10.2
16.25	454	80	70	335	74	4.2	13.6
17.75	502	85	76	354	106	6.4	17
20	578	85	76	390	142	11.5	26
23	660	110	100	457	207	23	40
26	749	110	100	492	272	38	57
29	838	130	115	552	358	65	78
32	914	130	115	587	520	95	106
36	1032	150	150	626	678	182	136

Premium Energy Transmission Limited

Head Office : P.B. No. 5, Chinchwad, Pune - 411 019, India. Tel. : (91-20) 27475141 / 42 / 43 / 44, Fax : (91-20) 27450287, 27476601.

Branch Offices : ● **Western Region :** **Mumbai :** Industry Manor, Appasaheb Marathe Marg, Prabhadevi, Mumbai - 400 025. Tel. : (91-22) 24223747, 24365510, Fax : (91-22) 24377730. **Ahmedabad :** "Jaldarshan", Ashram Road, Navrangpura, Ahmedabad - 380 009. Tel. : (91-79) 26580428/0518/1861, Fax : (91-79) 26587783. **Nagpur :** "Guman", Pandit Jawaharlal Nehru Marg, Sadar, P. B. No. 129, Nagpur - 440 001. Tel. : (91-712) 2526588, 2524125, 2526038, Fax : (91-712) 2541142. ● **Northern Region :** **New Delhi :** Express Building Annexe, 9-10, Bahadur Shah Zafar Marg, New Delhi - 110 002. Tel. : (91-11) 23730554 (8 lines), Fax : (91-11) 23359782. ● **Eastern Region :** **Kolkata :** Thapar House, 25, Brabourne Road, P. B. No. 702, Kolkata - 700 001. Tel. : (91-33) 22423811, 22423780, 22423805, Fax : (91-33) 22424325. **Ranchi :** Rani Kuthi, 82, Burdwan Compound, P.B. No. 139, Ranchi - 834 001. Tel. : (91-651) 2562651, Fax : (91-651) 2562027. ● **Southern Region :** **Chennai :** "Wavoo Mansion", 6th Floor, New No. 48, (Old No. 39), Rajaji Salai, Chennai - 600 001. Tel. : (91-44) 25240142, Fax : (91-44) 25224557. **Bangalore :** 16/3, Ali Asker Road, P. B. No. 216, Bangalore - 560 052. Tel. : (91-80) 22268773/2506, Fax : (91-80) 22253472. **Hyderabad :** 6-2-47, A. C. Guards, 1st floor, P. B. No. 9, Hyderabad - 500 004. Tel. : (91-40) 23314025, 23390544, 23316446, Fax : (91-40) 23318557. **Kochi :** 39/5567, M. G. Road, Ernakulam, Kochi - 682 015. Tel. : (91-484) 2359190, 2359372, Telefax : (91-484) 2359589.